



天猫店



淘宝网



阿里巴巴



微信



大昌货架官网



大昌钢构官网



阿里巴巴



# DACHANG

SUPERMARKET SHELVES

大昌超市货架



大昌超市货架

### 佛山市南海大昌货架有限公司

展销部: 广东省南海市大沥广佛公路谢边段(佛山机场路口)  
电话: 0757-83666833 83666878 85517683  
传真: 0757-81185888  
手机: 13902413538 13902410873 13902805934(区生)  
邮箱: dchangshelf@126.com dchj@dcsheif.com  
网址: <http://www.dcsheif.com/>

### Dachang Racking & Shelving Co., Nanhai, Foshan

Showroom: (0757)83666833 83666878 85517683  
Fax: (0757)81185888  
Mobile: 13902413538 13902410873 13902805934  
E-mail: dchangshelf@126.com dchj@dcsheif.com  
<http://www.dcsheif.com/>

### 佛山市南海谢边大昌钢构有限公司

厂址: 佛山市南海大沥桂丹路谢边大桥侧  
电话: 0757-81185133 85578889 83666833 85553056  
传真: 0757-81185888 85561031  
邮箱: dcgg@dcsheif.com  
网址: <http://www.dcosteels.com/>

### Dachang Steel Structure Co., Ltd. Xiebian, Nanhai Foshan

Address: Xiebian, Dali, Nanhai District, Foshan City, Guangdong Province  
Tel: (0757)81185133 85578889 83666833 85553056  
Fax: (0757)81185888 85561031  
E-mail: dcgg@dcsheif.com  
<http://www.dcosteels.com/>



佛山市南海大昌货架有限公司  
DACHANG RACKING & SHELVING CO., NANHAI, FOSHAN

2017-04版





## Contents 目录

- 003 ▶ 企业简介
- 007 ▶ 超市货架
  - DC-7型
  - DC-8型
  - DC-82型
  - DC-11型
  - DC-12型
  - DC-13型
  - DC-13四柱型
  - DC-15型
  - DC-17型
  - DC-18型
  - DC-19型
  - DC-19四柱型
  - DC-20型
  - DC-20B型
  - DC-22型
  - DC-26型
  - DC-27型
  - DC-28型
- 027 ▶ 木板式超市货架
  - DC-001型
  - DC-002型
- 029 ▶ 仓库货架
  - DC-16型
  - DC-33型
  - DC-36型
  - DC-66型
  - DC-92型
  - DC-713型
  - DC-718型
- 036 ▶ 超市配套系列
  - 购物篮
  - 促销架、出入口机
  - 果菜陈列架
  - 购物车
  - 收银台
  - 登高车
- 042 ▶ 挂钩图示

DACHANG  
SUPERMARKET SHELVES

您的货架全面解决方案专家

YOUR SHELF SOLUTION EXPERT



- ◆ 30年的货架设计制造经验 30 years experience in design and manufacture of the shelf
- ◆ 拥有最丰富的货架产品线 It has the most abundant shelf product line
- ◆ 提供最完善产品专业服务 We provide the most perfect products and professional services
- ◆ 产品远销欧美亚多个国家 The products are exported to Europe and Asia

合作伙伴  
Cooperative partner

一握大昌手 永远是朋友



SUPERMARKET SHELVES  
DACHANG

## 公司简介

### Company Introduction

广东省佛山市南海大昌货架有限公司是一家从事专业设计、制造、安装自选超市组合货架和仓库轻、重型货架以及商场配套产品（如购物车、购物篮、入口机、收银台）的生产厂家。公司位于广佛公路路边路段，交通运输十分方便，周围公共设施齐备，是一家颇具规模，设备先进的外向型企业，货架品种最为齐全。拥有一批基础扎实，素质较高的生产技术工人和专业设计人员。

本公司拥有展示货架品种50多个型号，300多种规格，能满足国内大型卖场整体设计和生产配套，其中重型仓库货架专业生产能力可达20米高，满足各层次客户的需求。始建于1987年，在公司领导的努力开拓下，不断发展扩大，近年更呈持续上升的趋势。在全国各地均设有分销机构，部分产品远销国外，深得中外用户的信赖，多次荣获“名优企业”称号。

多年来，本公司坚持经营理念：以优质的产品、良好的信誉、真诚服务社会为宗旨，依靠科学技术力量、先进设备和丰富的货架生产经验，竭诚为广大用户提供优质服务，欢迎各界人士垂询和惠顾。

Dachang Racking & Shelving Co., Ltd. Nanhai, established in 1987, specializes in designing, manufacturing and installing industrial & commercial light, medium and heavy-duty shelving and racking products, and also accessories. In 2008, we became the first manufacturer in China to be certified by E.U. standards.

(No.325 Highway) and Foshan Airport Road. We are surrounded by the networks of railway, freeway, river port and airport, with very convenient facilities of communication and transportation. After more than 20 years of development, the enterprise has now become one of the leading manufacturers in China and the most strong racking and shelving company in Guangdong, with a group of senior engineers, professional designers and technical personnel, fulfilling ISO9001:2000 certified quality standards, controlling and administering strictly the engineering design, production, inspection, construction and safe service. We have distributors all over the country and 60% of our products are exported overseas. Our concept is ensuring the quality and satisfying our international clients with good service. This concept has earned for us many accolades such as the titles of "Famous enterprise" and "Contract trustworthy enterprise" among others.

We supply our products to factories, mining, airports and logistics distribution. We always continue improving the design and production and we produce the series of supermarket shelves. We are able to produce the warehouse shelves with a height of 30 meters. We insist on this target: by perfect products, sincere service and a great reputation, by the technological power, advanced equipment and excellent skills, to earn the confidence from customers all over the world.



大昌产品远销国内外

The products are sold at home and abroad



大昌坚持发扬“创新、争先、全球共享”的精神，以“品牌国际化、产业科技化、管理现代化、市场全球化”为发展方向，站在全球的视野，持续创新，以卓越的品质为依托、以高科技产业为主旨，全力打造企业核心竞争力，寻求“互利共赢、共同发展”，持续不断地为国内外客户创造更多、更大的价值。

Dachang adhere to carry forward the "innovation and excellence, global sharing", "brand internationalization, industrial technology, modern management and market globalization" as the direction of development, from the global perspective, continuous innovation, excellent quality, relying on high-tech industries purpose, to build the core competitiveness of enterprises, seeking mutual benefit "mutual benefit, common development", continuously for domestic and foreign customers to create more and more value.





DC-7型  
Type DC-7

用途与特点:

DC-7型货架, 可配背板、背网式超市货架, 款式新颖、大方, 组合多元化, 活动基脚与立柱连接, 结构合理, 运输方便, 适用于小型超市、便利店、加盟店等。  
双面4层, 每层均载35Kg/层;  
单面4层, 每层均载25Kg/层。

DC-7 supermarket shelf can be matched with mesh back and board back, looks fashionable and attractive. removable footing and post structure offers convenience for package and transportation; Variable combination with different accessories varies display functions easily.

DC-7

形式M	长度L	层板W	高度H
单面	660	顶200 中250 底300	1350 1500 1800 2000
双面	900		

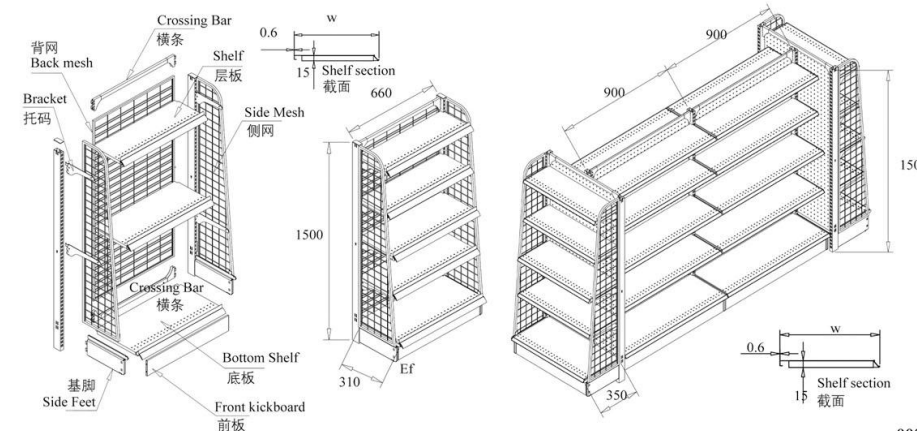
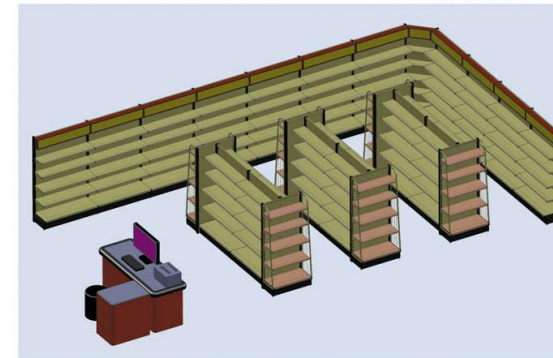

## DC-8型 Type DC-8

### 用途与特点:

DC-8型超市货架有背网和铁背式两种形式, 具有承载大结构力强的特点, 安装组合方便简洁, 特别适合中小型超市卖场的特点。

双面4层, 每层均载60Kg/层;  
单面4层, 每层均载50Kg/层。

DC-8 supermarket shelf can be matched with mesh back and board back, looks fashionable and attractive. removable footing and post structure offers convenience for package and transportation; Variable combination with different accessories varies display functions easily.



DC-8

形式M	长度L	层板W	高度H
单面	900	中300	1300
双面	900	底400	1500
端头	760		1600
			1800
			2000

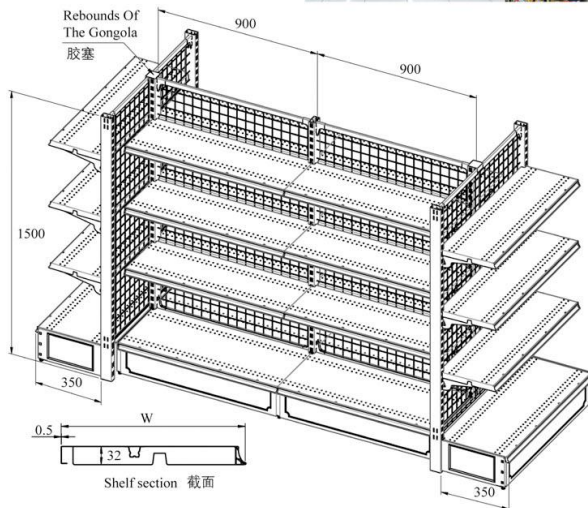

## DC-82型 Type DC-82

### 用途与特点:

1、可主付架连接, 均载50kg/层。  
2、DC-8型超市货架有背网和铁背式两种, 活动连接基脚, 安装组合方便, 特别适合中小型超市卖场使用。

双面4层, 每层均载60Kg/层;  
单面4层, 每层均载50Kg/层。

### Main Features:

1) Sharable post for adding bay to save cost. Loading capacity: 50kg/Level.  
2) Mesh backed and board-backed available, removable footing design, especially suitable for small or medium size supermarkets.

DC-82

形式M	长度L	层板W	高度H
单面	900	中300	1300
双面	900	底400	1500
端头	760		1800
			2000

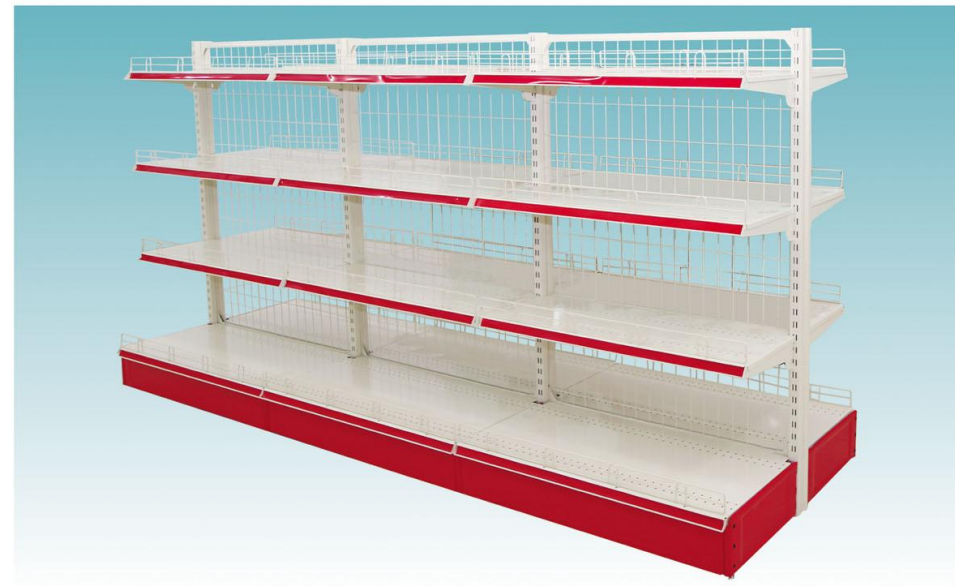
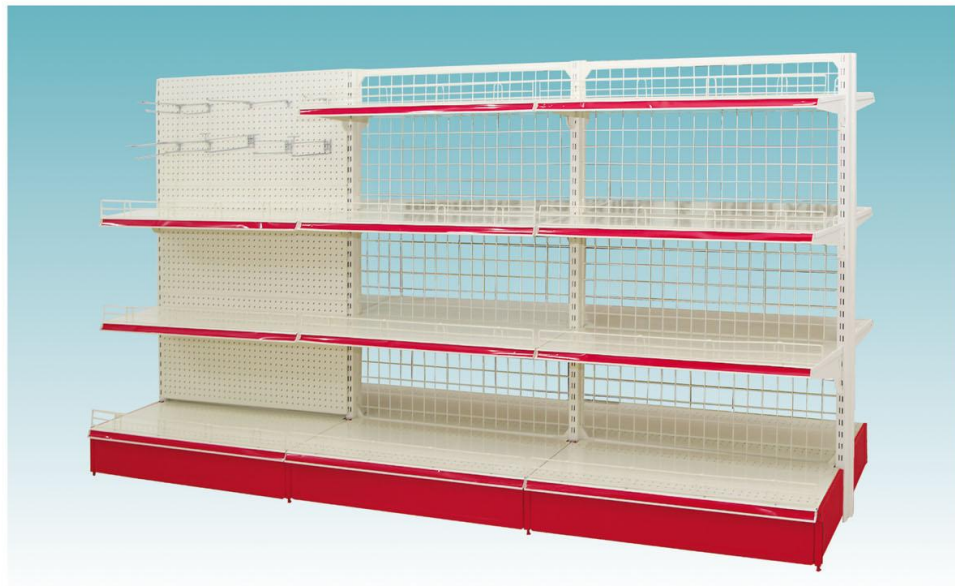
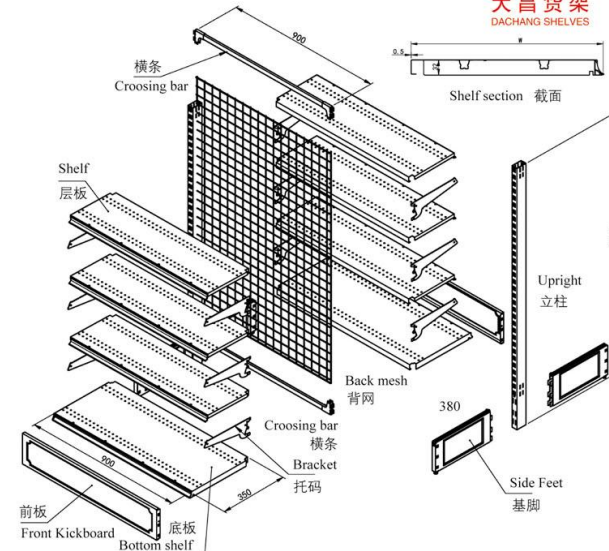

DC-11型  
Type DC-11



用途与特点:  
1、DC-11超市货架背板式固定焊接, 基脚与立柱一体化。  
2、安装快捷, 组合方便, 可主付架连接, 适合中小型超市卖场使用。  
双面4层, 每层均载60Kg/层;  
单面4层, 每层均载50Kg/层。

1)Sharable posts between two bays can save cost.  
2)quicker installation, suitable for small or medium-sized supermarket.



DC-11

形式M	长度L	层板W	高度H
单面	900	顶250	1300
双面	900	中300	1500
端头	720	底350	1600
			1800
			2000

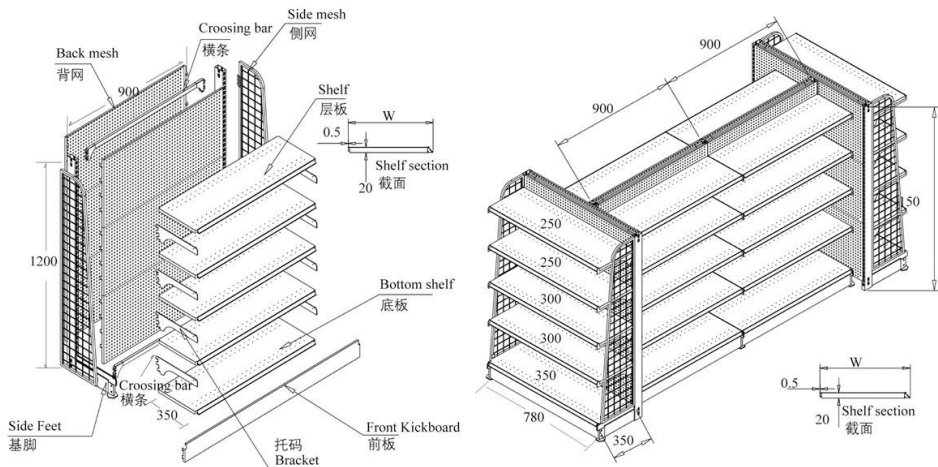

DC-12型  
Type DC-12



用途与特点:  
DC-12型铁背式货架款式新颖大方, 配置灵活, 活动基脚组合, 双面组合自由, 经济优越明显。  
双面4层, 每层均载100Kg/层;  
单面4层, 每层均载80Kg/层。

DC-12 supermarket shelf can be matched with mesh back and board back, looks fashionable and attractive. removable footing and post structure offers convenience for package and transportation; Variable combination with different accessories varies display functions easily.

DC-12

形式M	长度L	层板W	高度H
单面	900	400	1400
双面	1200	450	1600
		500	1800
		550	2000
			2400

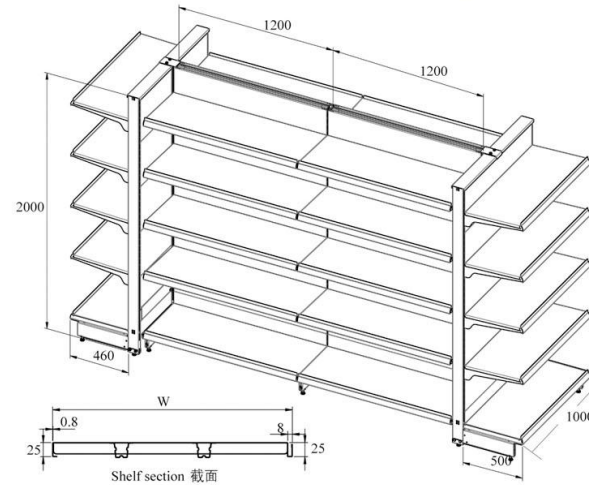



DC-13型  
Type DC-13



用途与特点:  
DC-13型货架, 全新设计, 载重量大, 组合方便, 层板一体成型, 层数可随意调整, 适合大型购物中心选用。

双面4层, 每层均载130Kg/层;  
单面4层, 每层均载100Kg/层。

DC-13 supermarket shelf can be matched with mesh back and board back, looks fashionable and attractive. removable footing and post structure offers convenience for package and transportation; Variable combination with different accessories varies display functions easily.



DC-13

形式M	长度L	层板W	高度H
单面	1300	400	1400
双面	1300	450	1600
		500	1800
		550	2000
		600	2400

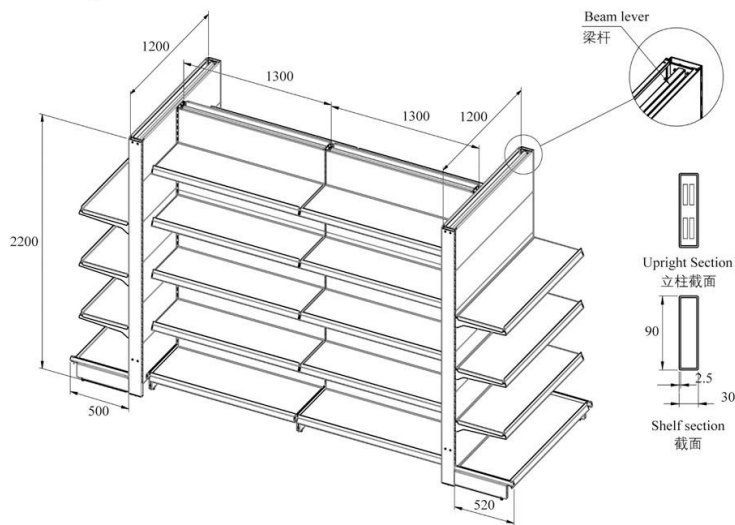

DC-13型 (四柱型)  
Type DC-13 (Four column type)



DC-13 (四柱型)

形式M	长度L	宽度W	高度H
单面	900	400	1500
双面	1200	450	1800
		500	2000
		550	2200
		600	2400

用途与特点:  
DC-13四柱型货架, 每层可承重100KG, 组合式, 安装方便, 背板用手拍进立柱内卡稳, 货架就非常稳固, 层板一体成型, 可用有机片当作前拦使用, 层数可以随意调整。

双面4层, 每层均载140Kg/层;  
单面4层, 每层均载130Kg/层。

DC-13 supermarket shelf can be matched with mesh back and board back, looks fashionable and attractive. removable footing and post structure offers convenience for package and transportation; Variable combination with different accessories varies display functions easily.

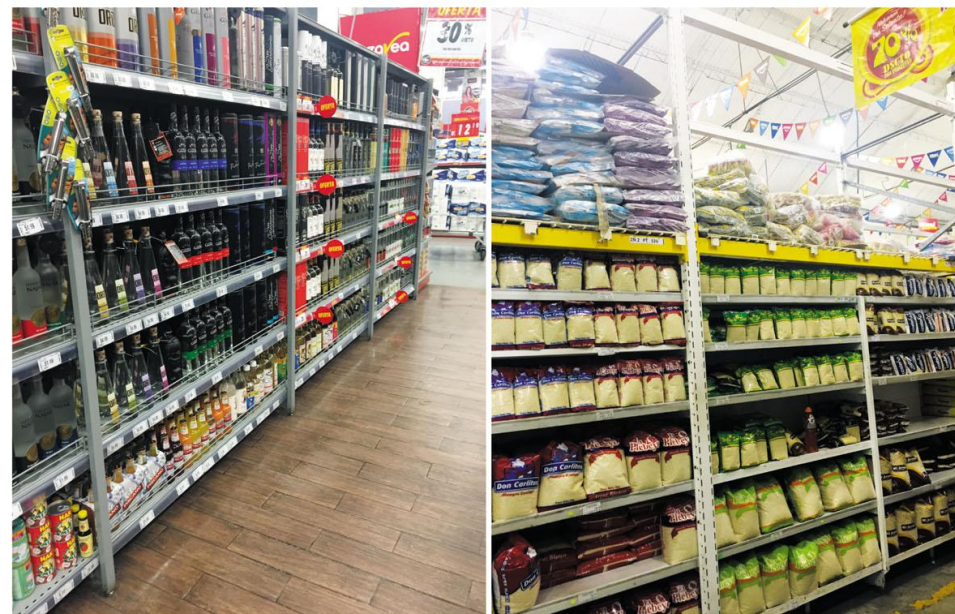



DC-15A型、DC-15B型、DC-15C型  
Type DC-15A、Type DC-15B、Type DC-15C



用途与特点：  
DC-15型货架，专业中小型  
高度设计生产，双面灵活组合，  
运输安装更方便，款式新颖大方，经济效益高。  
双面4层，每层均载50Kg/层；  
单面4层，每层均载40Kg/层。

DC-15 supermarket shelf can be matched with  
mesh back and board back, looks fashionable and at-  
tractive. removable footing and post structure offers  
convenience for package and transportation; Variable  
combination with different accessories varies display  
functions easily.



DC-15B型



DC-15C型



DC-15A型

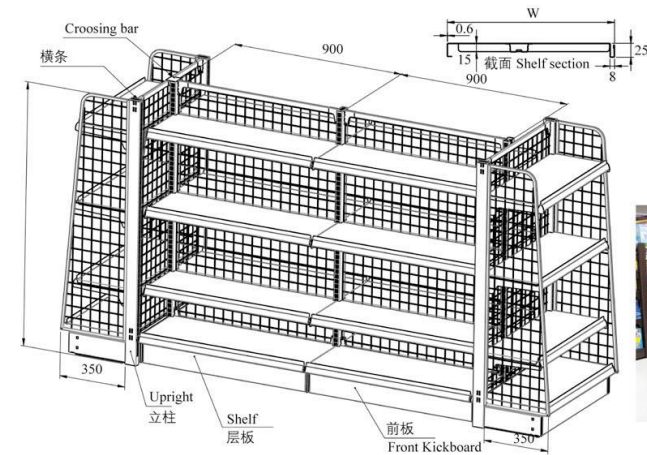

DC-15A、DC-15B			
形式M	长度L	层板W	高度H
单面	760	中300	1200
双面	900	底350	1500
端头	730		1800
			2000



DC-17A型  
Type DC-17A



DC-17A型(铁背板)

DC-17A

形式M	长度L	层板W	高度H
单面	900	350	1500
双面	1200	400	1800
		450	2000
		500	2200
		550	

用途与特点:

DC-17A型铁背板式超市货架, 款式新颖大方, 安装简洁方便, 层数可随意增减, 特别适合中型超市卖场使用, 是公司今年主推产品之一。

双面4层, 每层均载100Kg/层;  
单面4层, 每层均载80Kg/层。

DC-17A supermarket shelf can be matched with mesh back and board back, looks fashionable and attractive. removable footing and post structure offers convenience for package and transportation; Variable combination with different accessories varies display functions easily.



DC-17C型(冲孔板)

DC-17B型、DC-17C型  
Type DC-17B、Type DC-17C



DC-17B型(背网式)



DC-17B型(万通板)



用途与特点:

DC-17B、17C型背板式超市货架, 款式新颖大方, 安装简洁方便, 层数可随意增减, 特别适合中型超市卖场使用, 是公司今年主推产品之一。

双面4层, 每层均载80Kg/层;  
单面4层, 每层均载60Kg/层。

DC-17B、17C supermarket shelf can be matched with mesh back and board back, looks fashionable and attractive. removable footing and post structure offers convenience for package and transportation; Variable combination with different accessories varies display functions easily.

DC-17B、DC-17C

形式M	长度L	层板W	高度H
单面	900	400	1500
双面	1200	450	1800
		500	2000
		550	2200

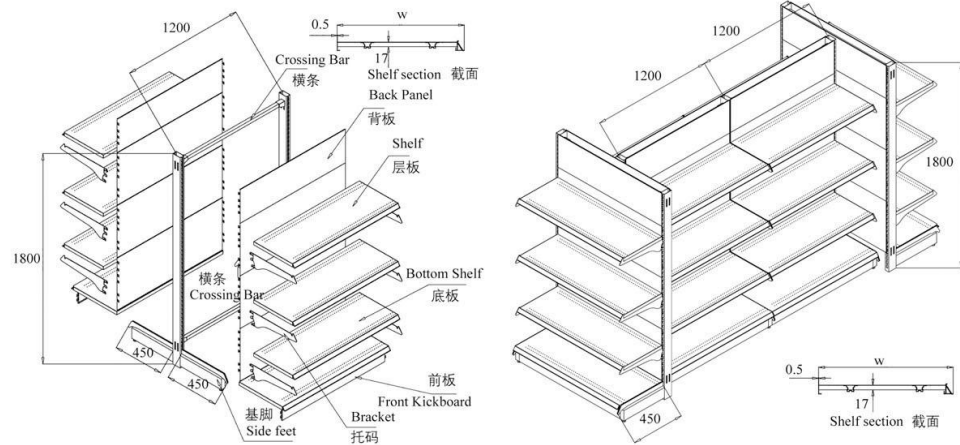

DC-18型  
Type DC-18



DC-18

形式M	长度L	层板W	高度H
单面	900	350	1500
双面	1200	400	1800
		450	2000
		500	2200
		550	
		600	



顶灯箱  
Top lamp box

用途与特点:

DC-18型背板式超市货架, 款式新颖大方, 安装简洁方便, 层数可随意增减, 特别适合中型超市卖场使用, 是公司今年主推产品之一。

双面4层, 每层均载100Kg/层; 单面4层, 每层均载80Kg/层。

Uses and characteristics:

DC-18 type backplane supermarket shelves, fashionable and generous, simple and convenient installation, the number of layers can be increased or decreased, especially suitable for the use of medium-sized supermarket stores, the company is one of the main push this year.

侧灯箱  
Side lamp box

可选玻璃层板

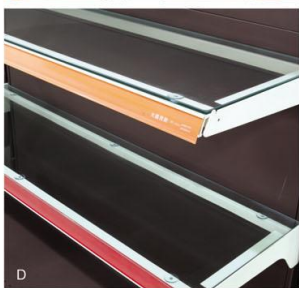
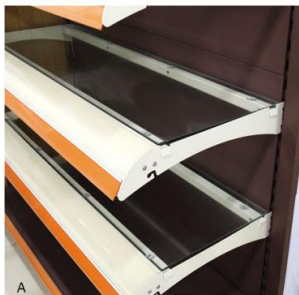

DC-19型、DC-19型(四柱型)  
Type DC-19、Type DC-19 (four column type)



用途与特点:  
DC-19型背板式超市货架, 款式新颖大方, 安装简洁方便, 层数可随意增减, 特别适合中型超市卖场使用, 是公司今年主推产品之一。

DC-19:

双面4层, 每层均载120Kg/层; 单面4层, 每层均载100Kg/层。

DC-19四柱型:

双面4层, 每层均载140Kg/层; 单面4层, 每层均载130Kg/层。

Uses and characteristics:

DC-19 type backplane supermarket shelves, fashionable and generous, simple and convenient installation, the number of layers can be increased or decreased, especially suitable for the use of medium-sized supermarket stores, the company is one of the main push this year.

DC-19、DC-19型(四柱型)

形式M	长度L	层板W	高度H
单面	900	350	1500
		400	1800
双面	1200	400	1800
		450	2000
		500	2200
		550	
		600	



DC-19型



DC-19型(四柱型)

DC-20型 (30x50立柱)  
Type DC-20

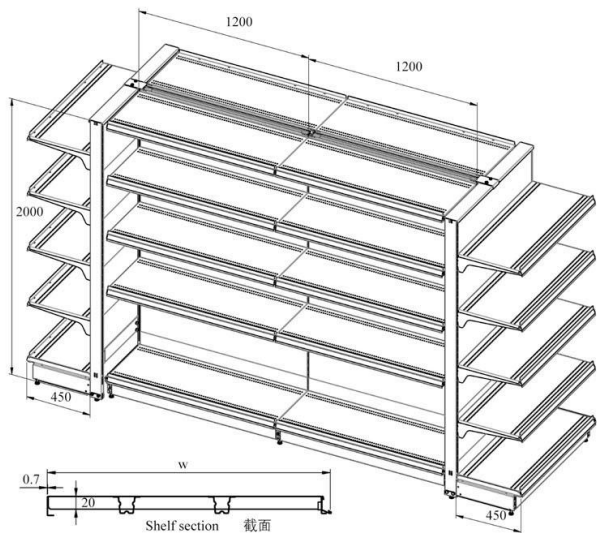

用途与特点:  
DC-20型铁背板货架, 款式新颖大方, 具有承载力大, 结构性强, 组合安装简洁方便层数可随意增减。

双面4层, 每层均载100Kg/层;  
单面4层, 每层均载90Kg/层。

DC-20 supermarket shelf can be matched with mesh back and board back, looks fashionable and attractive. removable footing and post structure offers convenience for package and transportation; Variable combination with different accessories varies display functions easily.

形式M	长度L	层板W	高度H
单面	900	400	1500
双面	1200	450	1800
		500	2000
		550	2200
			2400

DC-20B型 (30x60立柱)  
Type DC-20B



用途与特点:  
DC-20B型铁背板货架, 款式新颖大方, 具有承载力大, 结构性强, 组合安装简洁方便层数可随意增减。

双面4层, 每层均载90Kg/层;  
单面4层, 每层均载80Kg/层。

DC-20B supermarket shelf can be matched with mesh back and board back, looks fashionable and attractive. removable footing and post structure offers convenience for package and transportation; Variable combination with different accessories varies display functions easily.

形式M	长度L	层板W	高度H
单面	900	400	1500
双面	1200	450	1800
		500	2000
		550	2200
			2400



DC-22型  
Type DC-22



用途与特点：  
DC-22型铁背板货架，款式新颖大方，具有承载力大，结构性强，组合安装简洁方便层数可随意增减。

双面4层，每层均载100Kg/层；  
单面4层，每层均载80Kg/层。

DC-22 supermarket shelf can be matched with mesh back and board back, looks fashionable and attractive. removable footing and post structure offers convenience for package and transportation; Variable combination with different accessories varies display functions easily.

DC-22

形式M	长度L	层板W	高度H
单面	900	350	1500
双面	1200	400	1800
		450	2000
		500	2200
		550	2400

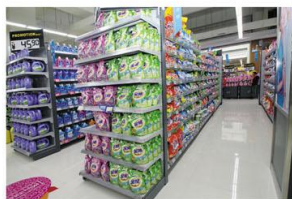
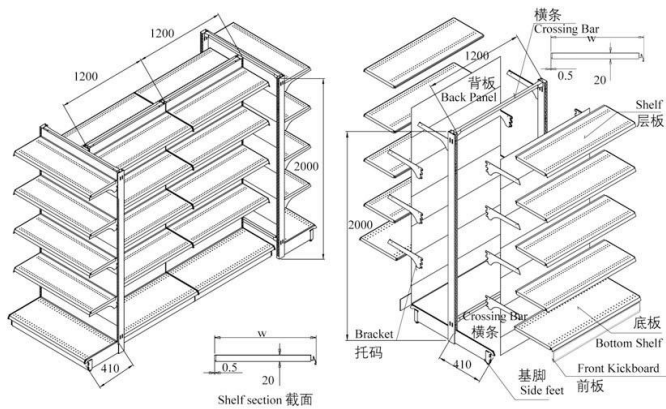

DC-26型  
Type DC-26



用途与特点：  
DC-26型单铁背板货架，配置灵活多变，满足各种使用功能，科学设计，提高商场的使用面积，使商品整齐摆置，突出了商品的实用性。

双面4层，每层均载120Kg/层；  
单面4层，每层均载100Kg/层。

Uses and characteristics:  
DC-26 type single iron backplate rack, flexible configuration, to meet the various functions, scientific design, improve the use of the mall area, so that the goods neatly placed, highlighting the practicality of the goods.

DC-26

形式M	长度L	层板W	高度H
单面	900	400	1500
双面	1200	450	1800
		500	2000
		550	2200
			2400



DC-27型  
Type DC-27



用途与特点：  
DC-27型货架，组合式，安装方便，背板直接挂在立柱孔内，货架就非常稳固，层板一体成型，可用有机片当前栏使用，层数可以随意调整。

双面4层，每层均载120Kg/层；  
单面4层，每层均载100Kg/层。

Uses and characteristics:  
DC-27 type shelf, combination, easy to install, directly linked to the back of the column in the hole, the shelf is very stable, laminated integrated molding, can be used as an organic column before the column, the number of layers can be adjusted.

DC-27

形式M	长度L	层板W	高度H
单面	900	300	1500
双面	1200	350	1800
		400	2000
		450	2200
		500	
		550	



DC-28型  
Type DC-28



用途与特点：  
DC-28型货架，组合式，安装方便，背板用手拍进立柱内卡稳，货架就非常稳固，层板一体成型，可用有机片当前栏使用，层数可以随意调整。

双面4层，每层均载120Kg/层；  
单面4层，每层均载100Kg/层。

Uses and characteristics:  
DC-28 type rack, combination type, convenient installation, back pat into column inside stable shelves is very solid, forming one plate, stopped using available organic layers can be adjusted freely as before.



DC-28

形式M	长度L	层板W	高度H
单面	900	400	1500
双面	1200	450	1800
		500	2000
		550	2200
			2400

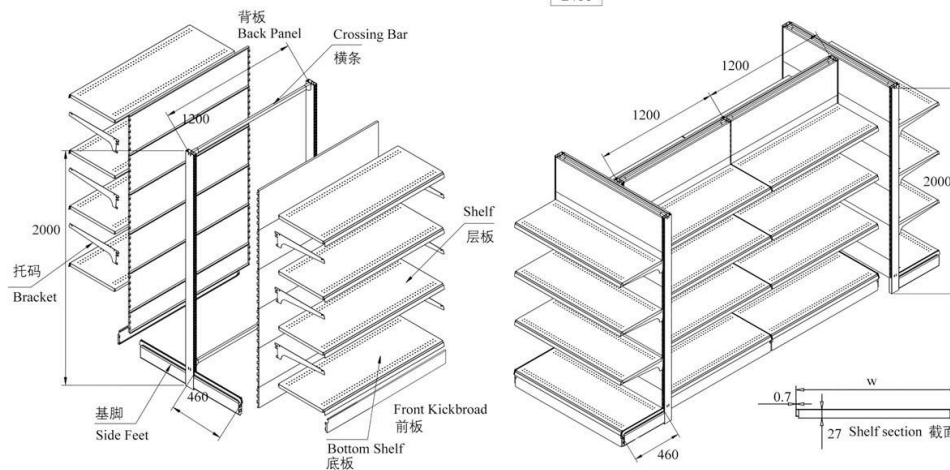



DF-001型、DF-002型 (木层板超市货架)  
Wooden supermarket shelves



DF-001型

用途与特点:  
木板式组合货架: 美观大方, 安装组合方便, 木板、铝合金条、新款塑胶角码与钢材的完美结合, 更能展现出此货架高雅大方的一面, 特别适用于中高档卖场使用。

DF-001型:  
双面4层, 每层均载60Kg/层; 单面4层, 每层均载40Kg/层。

DF-002型:  
双面4层, 每层均载40Kg/层; 单面4层, 每层均载30Kg/层。

Uses and characteristics:  
Wood combined shelves: beautiful appearance, convenient assembly, perfect combination of wood, Aluminum Alloy, new plastic and steel bracket, can show the elegant side shelf, especially suitable for use in high-end stores.

DF-001

形式M	长度L	层板W	高度H
单面	1200	中450	1500
双面	1200	底500	1800
			2000



DF-002型



DF-002

形式M	长度L	层板W	高度H
单面	900	中300	1500
双面	900	底350	1800
			2000



**DC-16型**  
Type DC-16

可主付架连接，组装方便快捷，适合办公室，家庭使用。均载500KG/层  
2000mmx600mmx2000mm

Can be connected to the main frame, easy to assemble, suitable for office, home use are loaded 500KG/ layer.

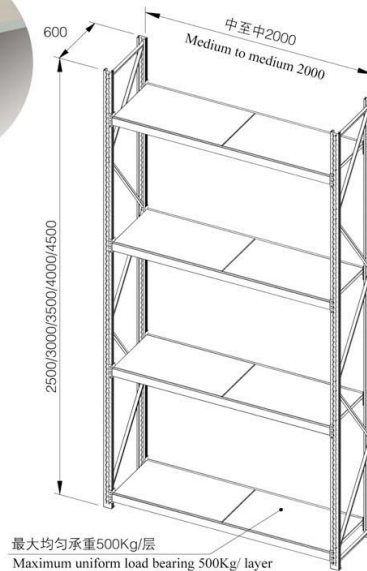
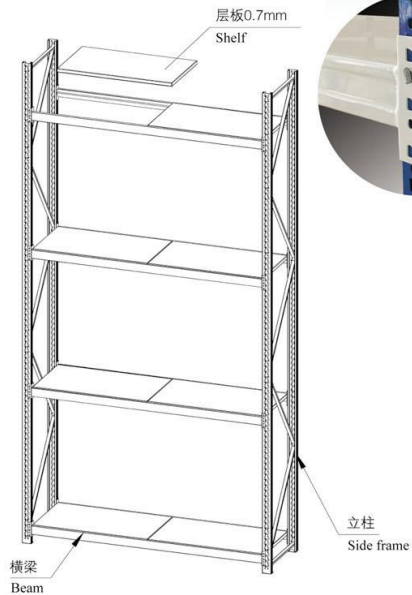

**DC-33型**  
Type DC-33



可主付架连接，组装方便快捷，适合办公室，家庭使用，中至中长1800x宽500x高1800mm，均载200-250KG/层。

Sharable post for adding bay to save cost, easy in installation. Loading capacity: 200-250kg /level, suitable for office and home furnishing. Inner L1800xW500xH1800

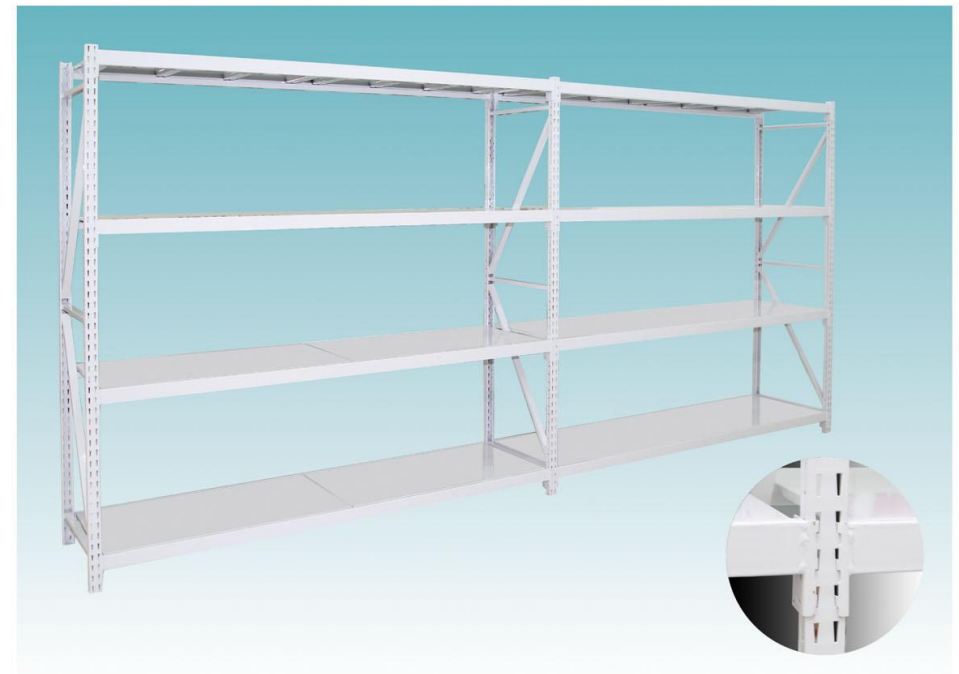
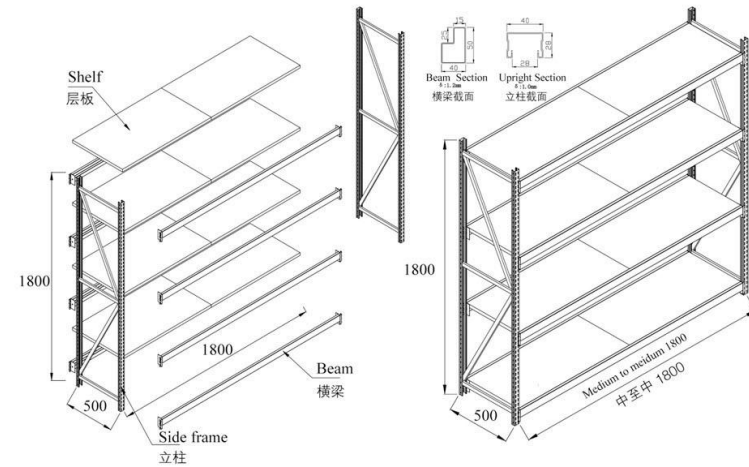

DC-36型  
Type DC-36

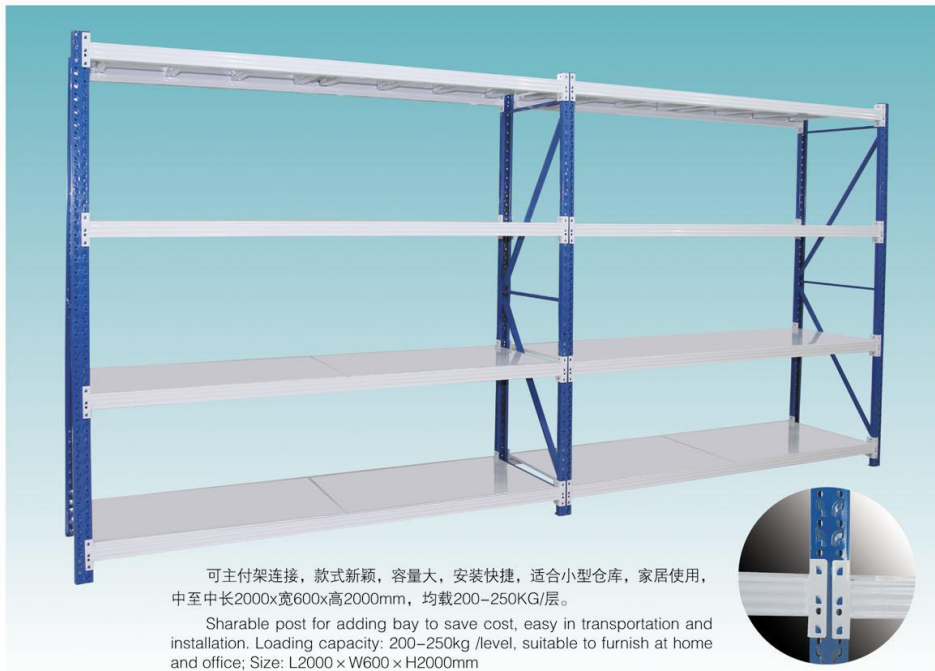

可主付架连接, 款式新颖, 容量大, 安装快捷, 适合小型仓库, 家居使用, 中至中长2000x宽600x高2000mm, 均载200-250KG/层。

Sharable post for adding bay to save cost, easy in transportation and installation. Loading capacity: 200-250kg /level, suitable to furnish at home and office; Size: L2000 x W600 x H2000mm

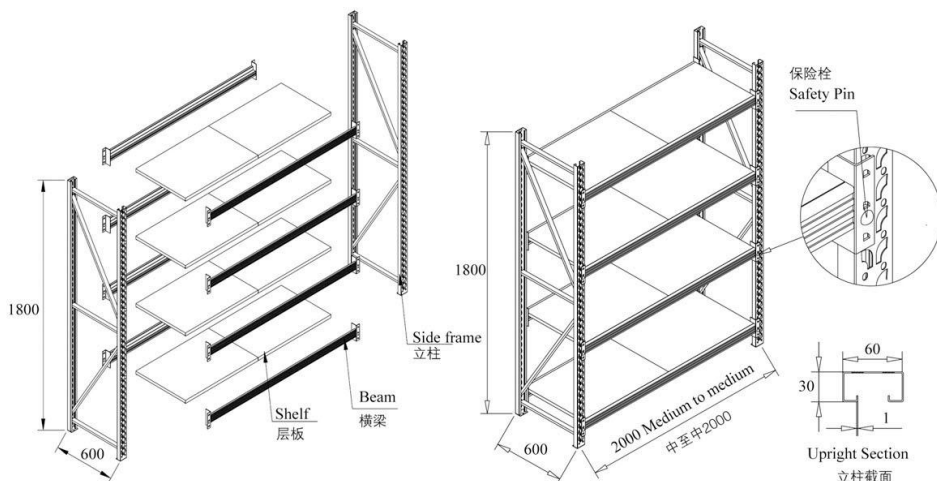

DC-66型  
Type DC-66

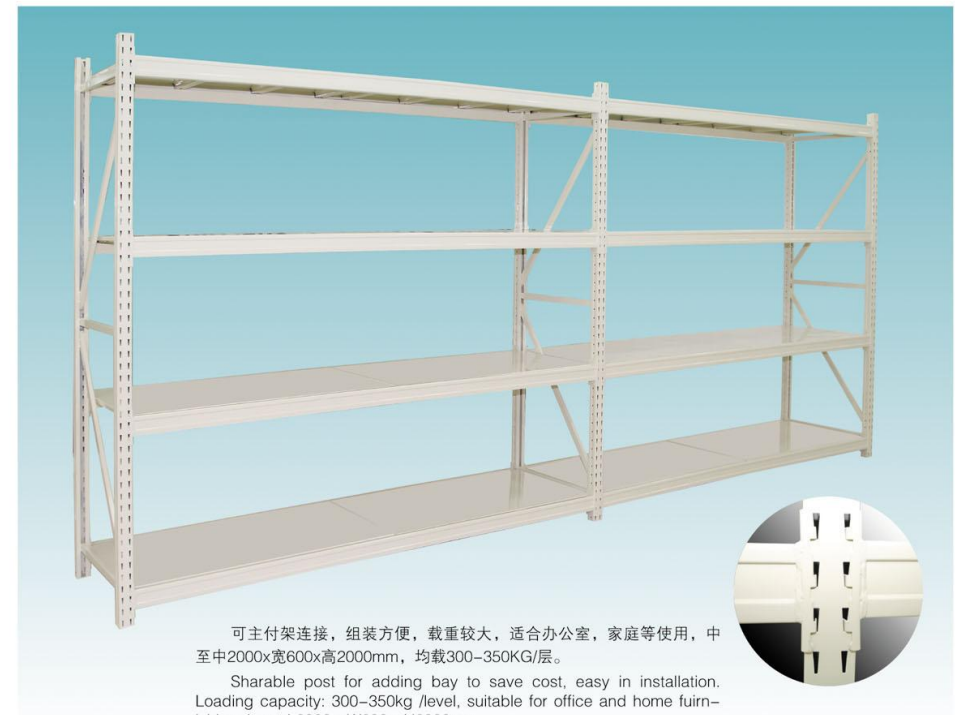
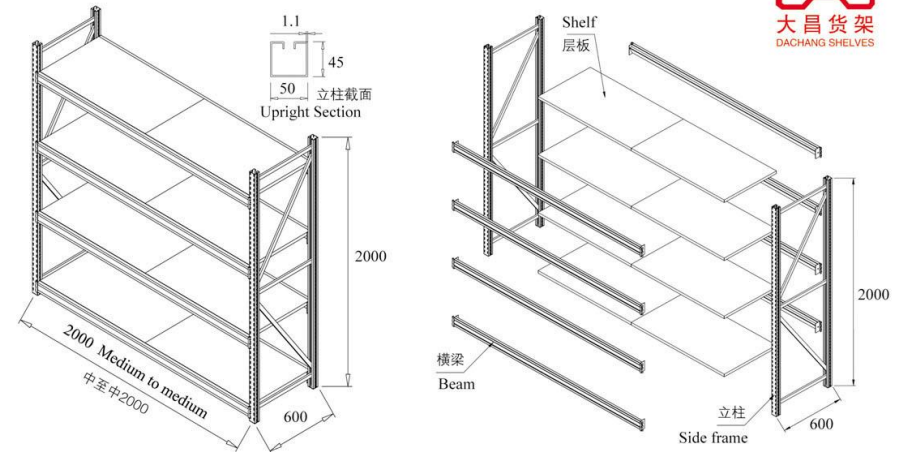

可主付架连接, 组装方便, 载重较大, 适合办公室, 家庭等使用, 中至中2000x宽600x高2000mm, 均载300-350KG/层。

Sharable post for adding bay to save cost, easy in installation. Loading capacity: 300-350kg /level, suitable for office and home furnishing. Inner L2000 x W600 x H2000mm

DC-92型  
Type DC-92



均载2000Kg/层以下的大昌仓库货架,具备使用灵活,安装方便,结构科学等良好构造性能,用途广泛,备受客商采用和好评。

All warehouse shelves 1000Kg/ Dachang layer below, with the use of flexible, convenient installation and good performance of the structure of scientific structure, wide use, has been using customers and praise.

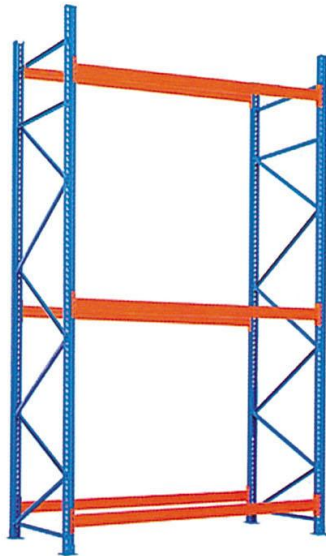
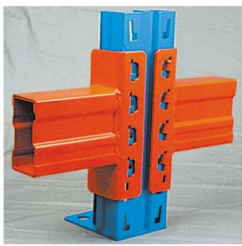

DC-713型、DC-718型  
Type DC-713、Type DC-718



DC-718



DC-713  
(注:端头背板另配)



用途与特点:  
四柱式货架, 可作仓库使用以方便补充或提取商品, 铁背式或铁背冲孔式背板可供选择, 安装方便, 深受中外客商欢迎。

Uses and characteristics:  
Four column type shelf, can be used as a warehouse to facilitate the replenishment or extraction of goods, iron back or iron back punch type backplane to choose from, easy to install, welcomed by domestic and foreign merchants.

DC-718、DC-713

形式M	长度L	宽度W	高度H
双面	1920	1200	2400
			2800
			3000



自动立体仓库货架、阁楼货架  
Automated Storage/Retrieval System,AS/RS、Mezzanine racking

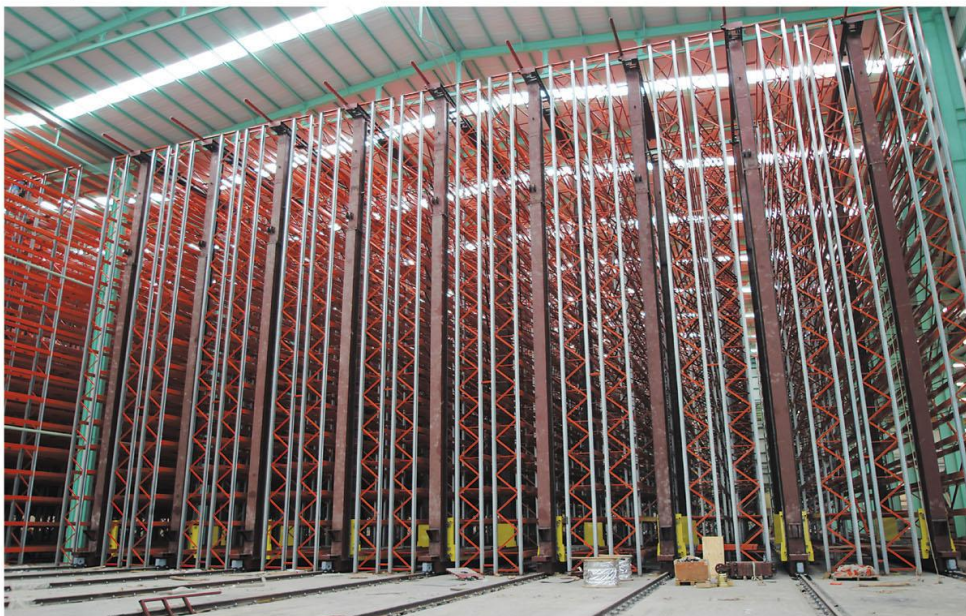

大昌厂内使用阁楼式货架(实景拍摄)

购物篮系列  
The shopping basket series

用途与特点：  
超市配套品种多样，选择丰富，满足不同需求的你，不同的款式供不同的卖场选择，灵活组合，款式新颖多变。

supermarket shelf can be matched with mesh back and board back, looks fashionable and attractive. removable footing and post structure offers convenience for package and transportation; Variable combination with different accessories varies display functions easily. Loading capacity: 30kg /level



购物篮001



购物篮002



购物篮009



购物篮003



购物篮004



购物篮005



购物篮006



购物篮007



购物篮008



购物篮010

促销架、出入口机  
Promotion rack, import and export machine

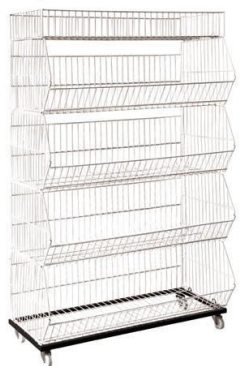

四层流动架  
规格:900x450x1400mm



折叠仓储笼  
规格:1000x800x820mm



电镀促销笼  
通规格:1200x800x900mm



促销台A



促销台B



双面出入口机



单面出入口机



豪华出入口机

果菜陈列架  
Fruit and vegetable display



单层蔬果架  
Single fruit rack



普通蔬果架  
Ordinary fruit rack



豪华蔬果架  
Fruit and vegetable rack



双层蔬果架  
Double fruit rack

购物车系列  
Shopping cart series



180L购物车001



130L购物车002



90/100L购物车003



日式购物车004



购物车006



购物车007

收银台系列  
The checkout line



新款组合式收银台  
SIZE: 1930x660x825mm

快速收银台  
SIZE: 1180x1040x850mm



DC-096型收银台  
主台: (1600、1800、2000)x600x850mm  
副台: 600x600x850mm

DC-097型收银台  
主台: (1600、1800、2000)x600x850mm  
副台: 600x600x850mm



登高车  
Ladder truck











登高车A

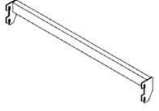
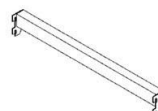
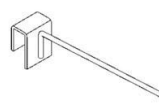
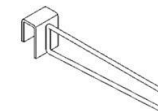
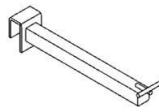
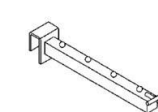
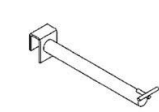
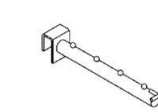
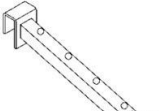
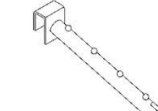
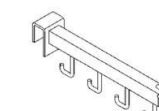

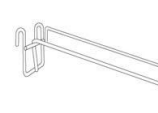

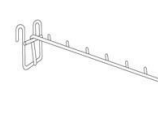

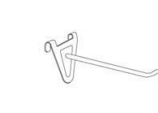
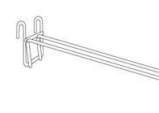
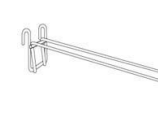
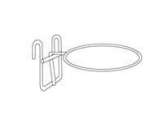
登高车C

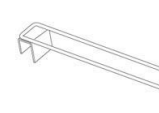
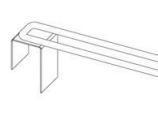
登高车B

超市货架挂钩系列  
Supermarket shelves hook series

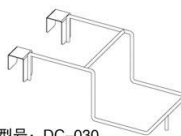
 型号: DC-001 规格: 15x30方管	 型号: DC-002 规格: 25x38方管	 型号: DC-003 单枝方管挂钩	 型号: DC-004 双枝方管挂钩
 型号: DC-007 方管直挂钩	 型号: DC-008 方管直珠挂钩	 型号: DC-009 圆管直挂钩	 型号: DC-010 圆管珠挂钩
 型号: DC-013 方管斜珠挂钩	 型号: DC-014 圆管斜珠挂钩	 型号: DC-015 方管倒钩挂钩	 型号: DC-016 鹅颈带针挂钩
 型号: DC-005 单枝网挂钩	 型号: DC-006 双枝网挂钩	 型号: DC-011 电工具网挂钩	 型号: DC-011 带珠网挂钩
 型号: DC-017 球鞋网挂钩	 型号: DC-018 V型单枝挂钩	 型号: DC-019 U型网挂钩	 型号: DC-020 回型网挂钩
 型号: DC-021 塑料桶挂钩	 型号: DC-022 单枝平孔挂钩	 型号: DC-023 平行挂钩	 型号: DC-024 回型平行挂钩

超市货架挂钩系列  
Supermarket shelves hook series

 <p>型号: DC-025 球笼陈列架</p>	 <p>型号: DC-026 球类挂钩</p>	 <p>型号: DC-027 双枝平孔挂钩</p>	 <p>型号: DC-028 平孔空调挂钩</p>
 <p>型号: DC-029 鞋托架挂钩</p>	 <p>型号: DC-030 鞋托架挂钩</p>	 <p>型号: DC-031 斜口笼</p>	 <p>型号: DC-032 斜口笼分隔网</p>
 <p>型号: DC-033 菜盘架挂钩</p>	 <p>型号: DC-034 碟架挂钩</p>	 <p>型号: DC-035 碗架挂钩</p>	 <p>型号: DC-036 圆型挂钩</p>
 <p>型号: DC-037 网层板组合</p>	 <p>型号: DC-038 玻璃层板组合</p>	 <p>型号: DC-039 单枝扣板挂钩</p>	 <p>型号: DC-040 双枝扣板挂钩</p>
 <p>型号: DC-041 U型斜口篮组合</p>	 <p>型号: DC-042 斜口笼分隔网</p>	 <p>型号: DC-043 空调挂钩</p>	 <p>型号: DC-044 球类围网</p>

**DACHANG**  
SUPERMARKET SHELVES